

Deep Face Flush Utility / Thick Finish Flush
Product Code: DFFU

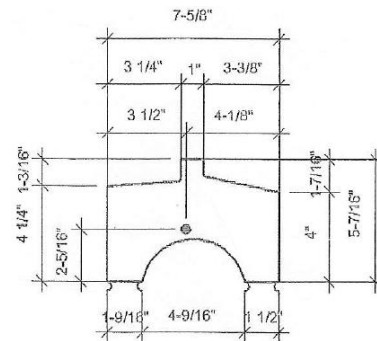

Deep Face Flush / Thick Flush Sill
Product Code: DFF

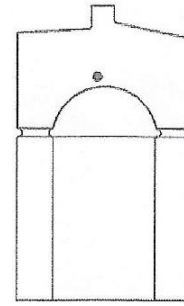
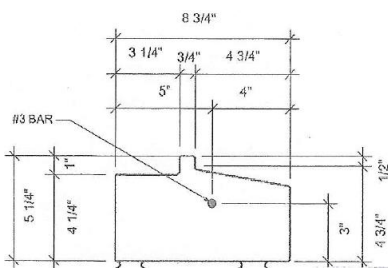
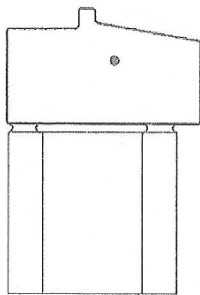

Deep Face / Thick Tile Sill
Product Code: DF

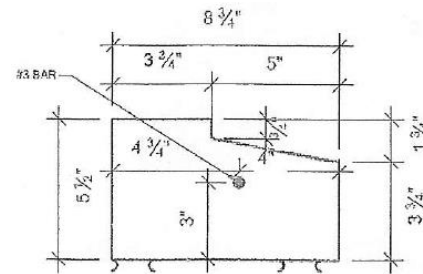
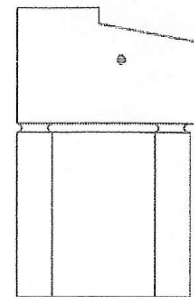

Deep Face Utility / Thick Finish Sill
Product Code: DFU

Actual dimensions within industry tolerances



Precast Details:
Sills
 Pg. 1

Standard Lengths:
 19", 26-1/2", 37", 48", 53", 60" & 74"
 Special lengths available upon request.

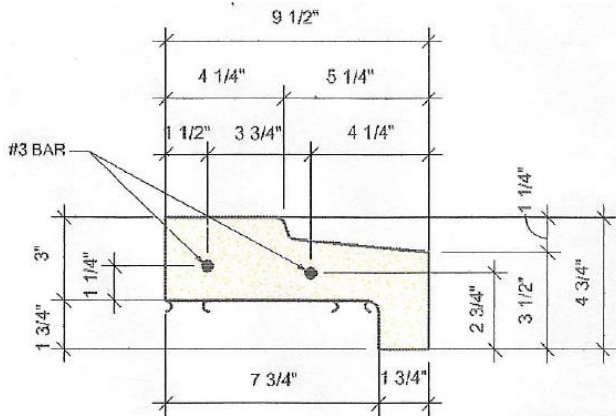
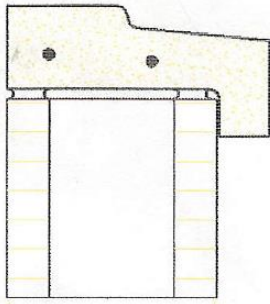

Wind Resistant Face / Wind Tile Sill
Product Code: F

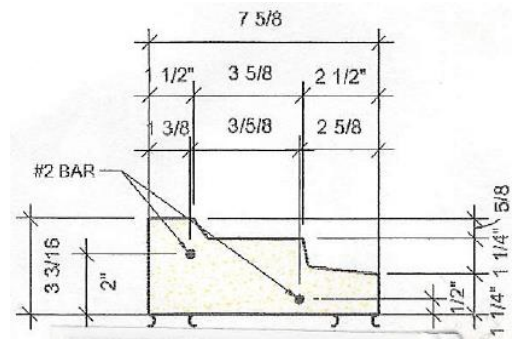
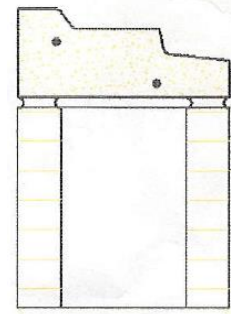

3-Step Storm Stop / 3-Step
Product Code: 3S

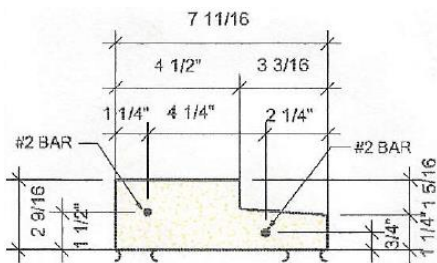
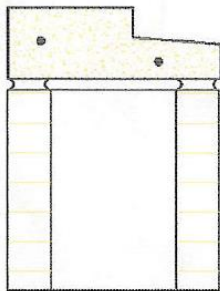

Wind Resistant / Wind Sill
Product Code: WR

Actual dimensions within industry tolerances



Precast Details:
Sills
Pg. 2

Standard Lengths:
19", 26-1/2", 37", 48", 53", 60" & 74"
Special lengths available upon request.